

Trade Price List

KITCHEN | LAUNDRY

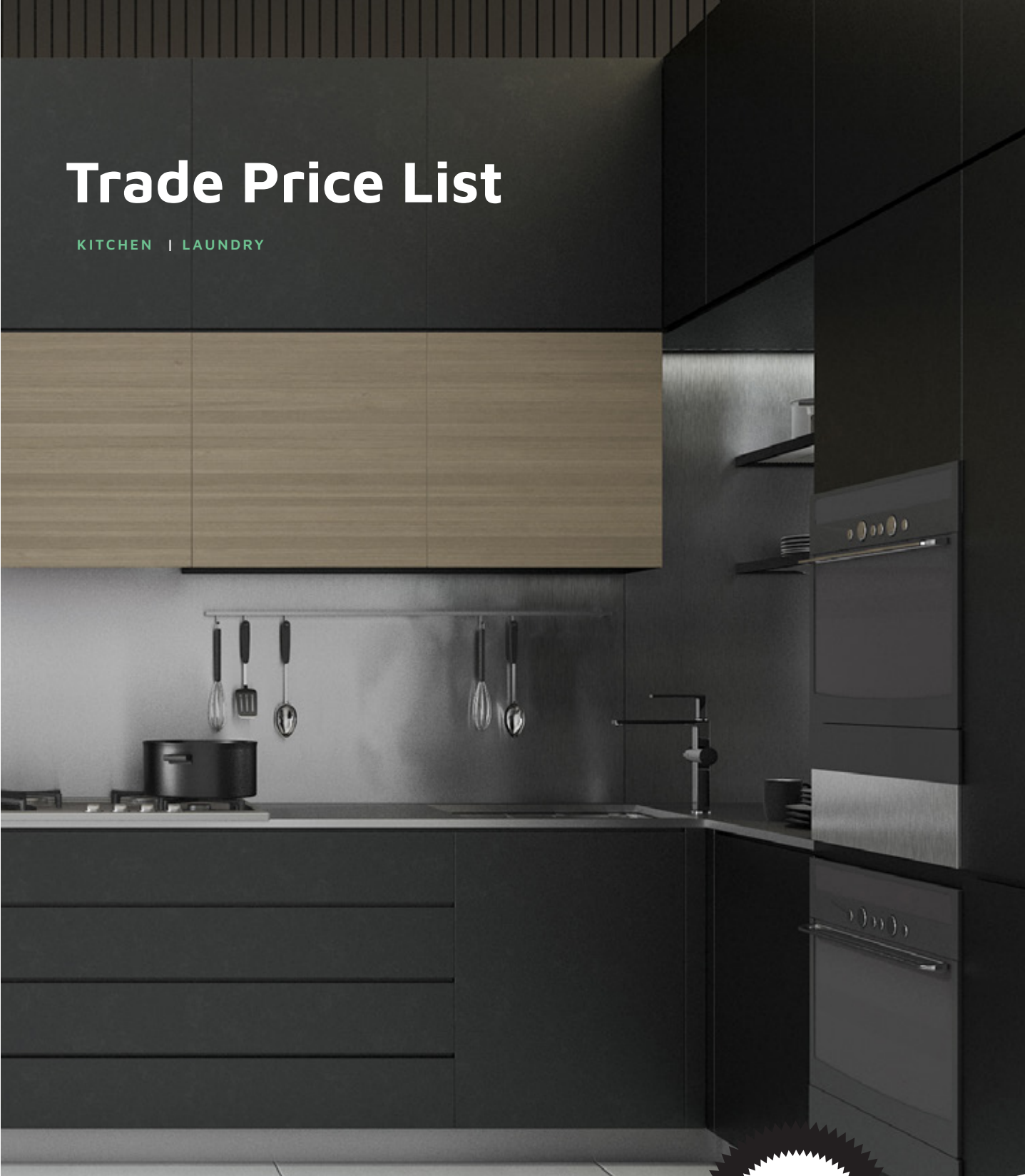

buycabinets
CUSTOM MADE IN A CLICK



Locally Made

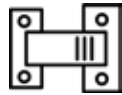

European Hardware



10 Year Warranty



Fully Assembled

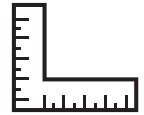

CNC Accuracy

CUSTOM MADE IN A CLICK!

Buy Cabinets are an Australian company specialising in the supply of custom made CNC cabinetry for Kitchens, Laundries, Bathrooms and Wardrobes.

Because we are the manufacturers and do not have the expense of retail showrooms, we can keep our costs low without the need to compromise on quality.

Our cabinets are Australian made, using Australian board from reputable suppliers. We can pre-assemble your cabinets for local pick up in Brisbane or Melbourne. Alternatively we can arrange delivery (assembled for metro locations, or flat packed for regional and interstate deliveries) POA.

Cabinet Specifications:

- Standard Carcass
 16mm White HMR Particle Board
 Custom available on request
- Doors, Drawer Fronts
 16mm or 18mm MR MDF Board
- Range of hardware from renowned brands
 Hafele and BLUM
 Custom available on requested

Getting Started

Obtaining a Quote

Option 1: Work out manually cost of kitchen using price list. To order send us a list of the products required.

Option 2: Send us builders plans or a sketch using our planner template and we will provide quote

3D Plans

Once you have accepted quote we will provide shop drawings for approval prior to manufacturing the cabinets.

Note: All quotes are based on measurements you provide

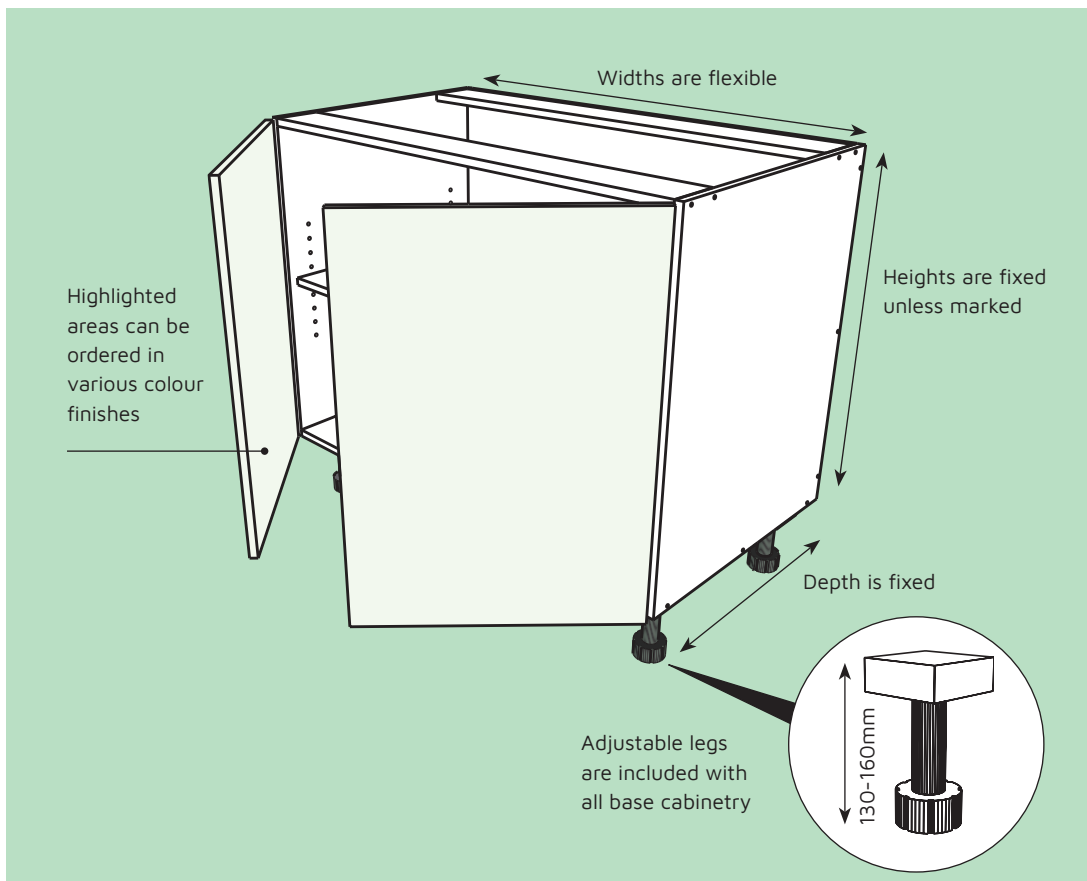

Contents

Colour Finishes	4
Kitchen Price Lists 6-14	
Base Cabinets	6
Drawer Cabinets	7
Overhead Cabinets	8
Pantry Cabinets	9
Appliance Cabinets	10
Open Shelf Cabinets	11
End Panels & Kicks	12
Hardware – Hinges	13
Hardware – Drawers	14
Bench Tops	16
Terms and Conditions	17
Warranty	20

How it Works:

There are various price options available for each product, we designed it this way to give you maximum flexibility depending on your budget and expectations.

Cabinet Sizes

All measurements are actual carcass size. Doors, drawer fronts and feet are not included in the measurement. Floor cabinets include feet which are adjustable from 130-160mm.

Custom Cabinet Widths

All cabinets are made to the exact width you require, we have separated the pricing into width ranges, for ease of quoting.

Custom Cabinet Heights

Selected appliance and pantry units can be made to custom heights if required.

Cabinet Depths

All cabinets are fixed depths. If required we can custom make to your specifications POA.

PRICE CATEGORIES EXPLAINED:

Carcass only

Should you wish to provide your own fronts and end panels, Buy Cabinets offer carcass only supply, these can be pre drilled to suit your hardware and panels.

Complete Cabinet

When you select an option including drawers or doors, you will be supplied with doors and drawer fronts. You still need to specify hardware which is sold separately.

Hardware

Choose from a range of pre-selected hardware options to suit each cabinet. When purchasing hardware from us, you get all other required components (i.e. drawer backs and sides), and by default, cabinets are fully assembled.

If you have a specific requirement, you can request a quote for custom hardware, or supply your own.

Choice of colours

The areas highlighted in green on the product diagrams can be finished in various colours, see colour chart overleaf.

Trusted Brands:



Colour Finishes

Standard Ranges

Designed to be complementary, our standard ranges have been created from the most popular colours and finishes from Polytec. Blend unique textures, tones and finishes to achieve a contemporary look.

Custom

We can supply any colour from the Polytec or Laminex ranges, contact us for a quote.

Premium Finishes

Legato features a super matt, non-reflective finish for a subtle, understated look, imbued with lighter, timber tones.

Ravine showcases the best natural touch timber surface lightly coloured with warm and inviting shades.

Createc is an ultra high gloss surface that delivers sharp lines for a polished, sophisticated finish.

Blend your choices to capture the latest design trends and style your ideal kitchen.

Disclaimer: Colours displayed are a guide only and have been matched as closely as possible to actual product. For accurate colour selection refer to manufacturers colour swatch.

Trade White

16mm HMR Particleboard with white melamine surface

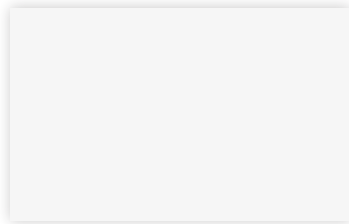

Decorator

16mm HMR MDF Board with Matt Finished Laminates



Designer

16mm HMR MDF Board with Sheen Finish on solid colours, or textured woodmatt finish on timber look laminates

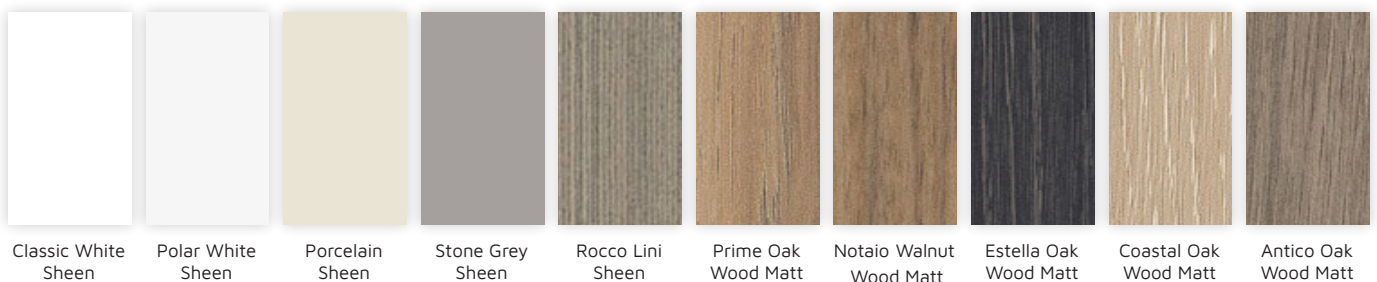

Premium

18mm HMR MDF Board with a SuperMatt non reflective finish on solid colours, or natural touch timber surface finish on the ravine range





Ravine Natural Oak and Classic White Matt combined for a light and breezy Coastal feel



Custom finishes available,
contact us directly for pricing

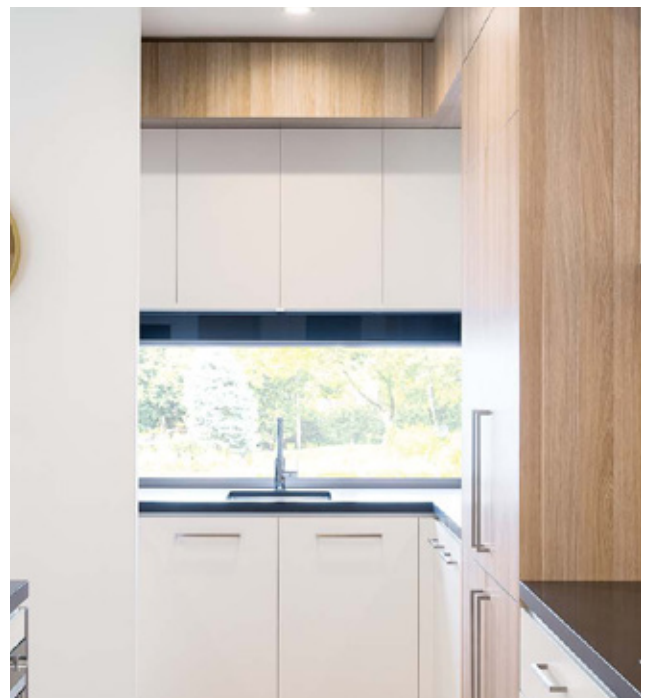

Base Cabinets

Carcass: White 16mm HMR Particle Board
 Door Fronts: MR MDF Board 16mm (WH, DE, DR) 18mm (PR)
 Measurements are carcass size not including doors.

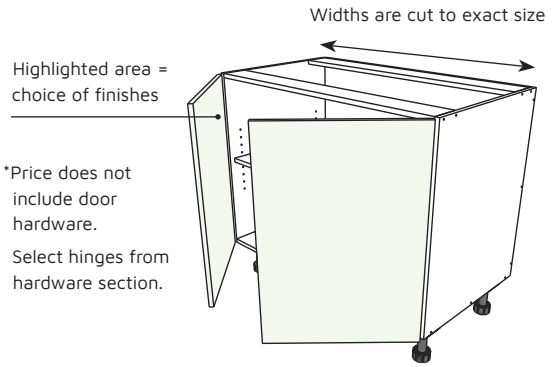

PRICE INCLUDING DOORS*			
Trade White WH	Decorator Range DE	Designer Range DR	Premium Range PR

Product Code Depth mm Height mm Custom Width mm Carcass Only CA

Base Cabinet Single Door

REQUIRES 2 X STANDARD OVERLAY HINGES PER CABINET



BCSD300^^	560	720	150-300	\$77.28	\$90.77	\$97.79	\$103.32	\$112.32
BCSD450^^	560	720	301-450	\$90.65	\$108.17	\$118.33	\$126.27	\$139.05
BCSD600^^	560	720	451-600	\$100.71	\$122.85	\$136.46	\$147.11	\$164.27
BCSD750^^	560	720	601-750	\$110.78	\$136.34	\$152.80	\$165.55	\$185.89
BCSD900^^	560	720	751-900	\$120.84	\$150.43	\$170.03	\$185.20	\$209.31

Base Cabinet Double Door

REQUIRES 4 X STANDARD OVERLAY HINGES PER CABINET



BCDD450^^	560	720	300-450	\$90.65	\$113.61	\$124.49	\$133.15	\$147.37
BCDD600^^	560	720	451-600	\$100.71	\$127.69	\$141.72	\$152.79	\$170.79
BCDD750^^	560	720	601-750	\$110.78	\$141.78	\$158.96	\$172.43	\$194.21
BCDD900^^	560	720	751-900	\$120.84	\$155.87	\$176.19	\$192.08	\$217.63
BCDD1050^^	560	720	901-1050	\$130.91	\$170.56	\$194.33	\$212.92	\$242.85
BCDD1200^^	560	720	1051-1200	\$140.97	\$185.25	\$212.46	\$233.76	\$268.07

Base Cabinet Corner 2 Door

REQUIRES 2 X CARCASS CORNER, 2 X BIFOLD CORNER HINGES



BC90CNR900^^	560	720	800-900	\$204.32	\$239.35	\$259.67	\$275.56	\$301.11
BC90CNR1000^^	560	720	901-1000	\$230.86	\$265.89	\$286.21	\$302.09	\$327.65

Base Cabinet Corner 3 Door

REQUIRES 2 X CARCASS CORNER, 2 X BIFOLD CORNER, 2 X STANDARD OVERLAY HINGES



BC90CNR1160^^	560	720	860*1160	\$232.72	\$273.19	\$294.23	\$310.83	\$337.83
BC90CNR1460^^	560	720	1010*1460	\$291.05	\$343.59	\$374.07	\$397.90	\$436.23

Base Cabinet Blind Single Door

REQUIRES 2 X BLIND CORNER HINGES



BCBSD1010^^	560	720	850-1010	\$148.25	\$187.90	\$211.67	\$230.26	\$260.19
BCBSD1160^^	560	720	1011-1160	\$161.66	\$205.94	\$233.16	\$254.46	\$288.77

Base Cabinet Blind Double Door

2 X BLIND CORNER, 2 X STANDARD OVERLAY HINGES



BCBDD1160^^	560	720	1010-1160	\$161.66	\$210.78	\$238.42	\$260.14	\$295.29
-------------	-----	-----	-----------	-----------------	----------	----------	----------	----------

USING THIS PRICE LIST

1 Choose your cabinets

2 Select hardware – page 13

Drawer Cabinets

Carcass: White 16mm HMR Particle Board
 Drawer Fronts: MR MDF Board 16mm (WH, DE, DR) 18mm (PR)
 Measurements are carcass size not including drawers.

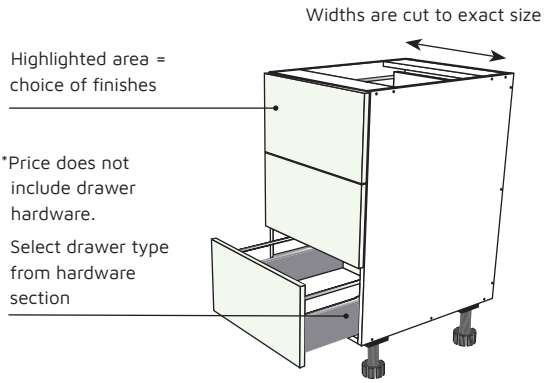

PRICE INCLUDING DRAWER FRONTS*			
Trade White WH	Decorator Range DE	Designer Range DR	Premium Range PR

Base Cabinet 1 Drawer REQUIRES 1 X DRAWER HARDWARE



Product Code	Depth mm	Height mm	Custom Width mm	Carcass Only CA	Trade White WH	Decorator Range DE	Designer Range DR	Premium Range PR
BC1DR450^^	560	720	450	\$90.65	\$106.54	\$123.33	\$133.66	\$147.88
BC1DR600^^	560	720	451-600	\$100.71	\$119.12	\$141.99	\$154.81	\$172.80
BC1DR750^^	560	720	601-750	\$110.78	\$131.71	\$160.66	\$175.95	\$197.73
BC1DR900^^	560	720	751-900	\$120.84	\$144.29	\$179.32	\$197.10	\$222.65

Base Cabinet 2 Drawer REQUIRES 2 X DRAWER HARDWARE



BC2DR450^^	560	720	450	\$90.65	\$110.99	\$127.78	\$138.56	\$153.23
BC2DR600^^	560	720	451-600	\$100.71	\$123.72	\$146.59	\$160.01	\$178.60
BC2DR750^^	560	720	601-900	\$110.78	\$136.46	\$165.41	\$181.45	\$203.98
BC2DR900^^	560	720	601-900	\$120.84	\$149.19	\$184.22	\$202.90	\$229.35

Base Cabinet 3 Drawer REQUIRES 3 X DRAWER HARDWARE

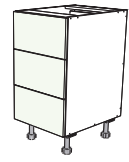

BC3DR450^^	560	720	450	\$90.65	\$115.44	\$132.23	\$143.46	\$158.58
BC3DR600^^	560	720	451-600	\$100.71	\$128.32	\$151.19	\$165.21	\$184.40
BC3DR750^^	560	720	601-750	\$110.78	\$141.21	\$170.16	\$186.95	\$210.23
BC3DR900^^	560	720	751-900	\$120.84	\$154.09	\$189.12	\$208.70	\$236.05

Base Cabinet 4 Drawer REQUIRES 4 X DRAWER HARDWARE



BC4DR450^^	560	720	450	\$90.65	\$119.89	\$136.68	\$148.36	\$181.22
BC4DR600^^	560	720	451-600	\$100.71	\$132.92	\$155.79	\$170.41	\$212.30
BC4DR750^^	560	720	601-750	\$110.78	\$145.96	\$174.91	\$192.45	\$243.37
BC4DR900^^	560	720	751-900	\$120.84	\$158.99	\$194.02	\$214.50	\$274.45

Base Cabinet 5 Drawer REQUIRES 5 X DRAWER HARDWARE



BC5DR450^^	560	720	450	\$90.65	\$124.34	\$141.13	\$153.26	\$169.28
BC5DR600^^	560	720	451-600	\$100.71	\$137.52	\$160.39	\$175.61	\$196.00
BC5DR750^^	560	720	601-750	\$110.78	\$150.71	\$179.66	\$197.95	\$222.73
BC5DR900^^	560	720	751-900	\$120.84	\$163.89	\$198.92	\$220.30	\$249.45



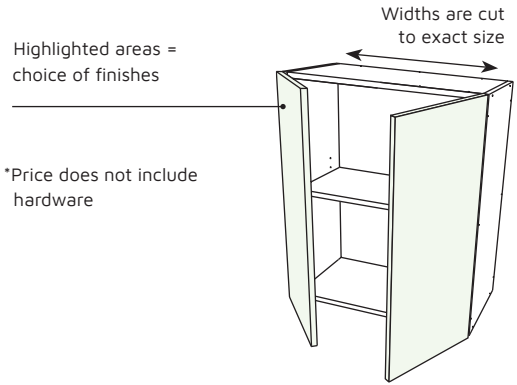

USING THIS PRICE LIST **1** Choose your cabinets **2** Select hardware – page 13

Overhead Cabinets

Carcass: White 16mm HMR Particle Board
 Door Fronts: MR MDF Board 16mm (WH, DE, DR) 18mm (PR)
 Measurements are carcass size not including doors.

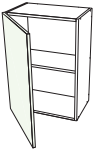

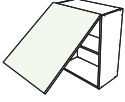
PRICE INCLUDING DOORS*

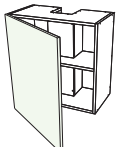
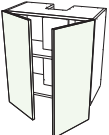
Product Code	Depth mm	Height mm	Custom Width mm	Carcass Only CA	Trade White WH	Decorator Range DE	Designer Range DR	Premium Range PR
Single Door REQUIRES 2 X STANDARD OVERLAY HINGES								
 OCSD300^^	280	720	150-300	\$52.76	\$66.25	\$73.26	\$78.80	\$87.80
OCSD450^^	280	720	301-450	\$59.52	\$77.03	\$87.19	\$95.14	\$107.91
OCSD600^^	280	720	451-600	\$72.89	\$95.03	\$108.63	\$119.28	\$136.44
OCSD750^^	280	720	601-750	\$79.65	\$105.21	\$121.66	\$134.42	\$154.76
OCSD900^^	280	720	751-900	\$86.41	\$116.00	\$135.59	\$150.76	\$174.87
Double Door REQUIRES 2 X STANDARD OVERLAY HINGES								
 OCDD450^^	280	720	300-450	\$59.52	\$82.47	\$93.35	\$102.02	\$116.23
OCDD600^^	280	720	451-600	\$72.89	\$99.87	\$113.89	\$124.96	\$142.96
OCDD750^^	280	720	601-750	\$79.65	\$110.65	\$127.82	\$141.30	\$163.08
OCDD900^^	280	720	751-900	\$86.41	\$121.44	\$141.75	\$157.64	\$183.19
Flap Door								
 OCFD300^^	280	720	150-300	\$52.76	\$66.25	\$73.26	\$78.80	\$87.80
OCFD450^^	280	720	301-450	\$59.52	\$77.03	\$87.19	\$95.14	\$107.91
OCFD600^^	280	720	451-600	\$72.89	\$95.03	\$108.63	\$119.28	\$136.44
OCFD750^^	280	720	601-750	\$79.65	\$105.21	\$121.66	\$134.42	\$154.76
OCFD900^^	280	720	751-900	\$86.41	\$116.00	\$135.59	\$150.76	\$174.87
90 Degree Corner 2 Door REQUIRES 2 X CARCASS CORNER AND 2 X BIFOLD CORNER HINGES								
 OC90CNR900^^	280	720	900x900	\$179.10	\$223.38	\$250.60	\$271.90	\$306.21
Blind Corner Single Door REQUIRES 2 X BLIND CORNER HINGES								
 OCBSD600^^	280	720	600	\$85.16	\$112.14	\$126.16	\$137.23	\$155.23
OCBSD900^^	280	720	601-900	\$93.68	\$129.31	\$149.92	\$166.11	\$192.26
Rangehood Single Door REQUIRES 2 X STANDARD OVERLAY HINGES								
 OCRSD300^^	280	720	300	\$69.37	\$82.86	\$89.87	\$95.41	\$104.41
OCRSD450^^	280	720	301-450	\$76.13	\$93.64	\$103.80	\$111.75	\$124.52
OCRSD600^^	280	720	451-600	\$89.50	\$111.64	\$125.24	\$135.89	\$153.05
OCRSD750^^	280	720	601-750	\$96.26	\$121.82	\$138.27	\$151.03	\$171.37
OCRSD900^^	280	720	751-900	\$103.01	\$132.60	\$152.20	\$167.37	\$191.48
Rangehood Double Door REQUIRES 4 X STANDARD OVERLAY HINGES								
 OCRDD450^^	280	720	300-450	\$76.13	\$99.08	\$109.96	\$118.63	\$132.84
OCRDD600^^	280	720	451-600	\$89.50	\$116.48	\$130.50	\$141.57	\$159.57
OCRDD750^^	280	720	601-750	\$96.26	\$127.26	\$144.43	\$157.91	\$179.69
OCRDD900^^	280	720	751-900	\$103.01	\$138.04	\$158.36	\$174.25	\$199.80

USING THIS PRICE LIST

1 Choose your cabinets

2 Select hardware - page 13

Pantry Units

Carcass: White 16mm HMR Particle Board
 Door Fronts: MR MDF Board 16mm (WH, DE, DR) 18mm (PR)
 Measurements are carcass size not including doors.

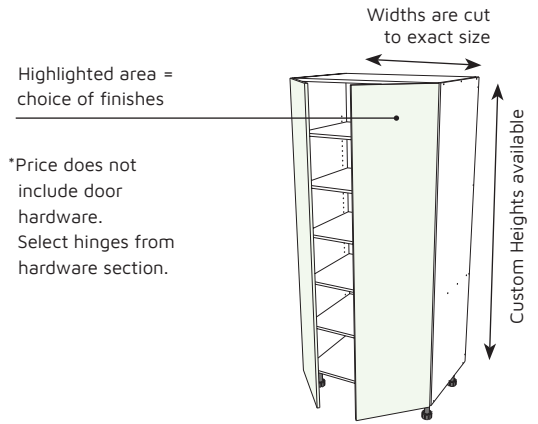

PRICE INCLUDING DRAWER FRONTS*

Product Code	Depth mm	Height mm	Custom Width mm	Carcass Only CA	Trade White WH	Decorator Range DE	Designer Range DR	Premium Range PR
--------------	----------	-----------	-----------------	-----------------	----------------	--------------------	-------------------	------------------

Pantry Cabinet Single Door REQUIRES 4 X STANDARD OVERLAY HINGES



PCSD450^^	560	2050	300-450	\$224.85	\$266.50	\$295.01	\$317.21	\$352.76
PCSD600^^	560	2050	451-600	\$255.12	\$307.95	\$345.28	\$374.20	\$420.23
PCHSD450^^	560	2051-2250	300-450	\$231.66	\$276.94	\$308.21	\$332.55	\$371.52
PCHSD600^^	560	2051-2250	451-600	\$258.62	\$316.16	\$357.10	\$388.81	\$439.27

Pantry Cabinet Double Door REQUIRES 8 X STANDARD OVERLAY HINGES

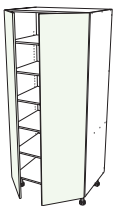

PCDD600^^	560	2050	up to 600	\$255.12	\$316.05	\$355.43	\$386.40	\$436.53
PCDD750^^	560	2050	601-750	\$282.08	\$354.19	\$402.39	\$440.08	\$500.69
PCDD900^^	560	2050	751-900	\$312.34	\$395.64	\$452.66	\$497.06	\$568.16
PCHDD600^^	560	2051-2250	up to 600	\$258.62	\$324.66	\$367.85	\$401.81	\$456.77
PCHDD750^^	560	2051-2250	601-750	\$288.89	\$367.18	\$420.05	\$461.38	\$527.83
PCHDD900^^	560	2051-2250	751-900	\$319.15	\$409.71	\$472.25	\$520.94	\$598.88

Pantry Cabinet Blind Single Door REQUIRES 4 X BLIND CORNER HINGES

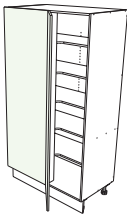

PCBSD860^^	560	2050	860	\$333.11	\$416.41	\$473.43	\$517.83	\$588.92
PCBSD1160^^	560	2050	861-1160	\$416.77	\$522.43	\$597.10	\$654.93	\$746.99
PCHBSD860^^	560	2051-2250	860	\$373.62	\$464.18	\$526.72	\$575.41	\$653.35
PCHBSD1160^^	560	2051-2250	861-1160	\$437.46	\$552.53	\$634.42	\$697.84	\$798.76

USING THIS PRICE LIST

1 Choose your cabinets

2 Select hardware - page 13

Appliance Cabinets

Carcass: White 16mm HMR Particle Board
 Door/Drawer Fronts: MR MDF Board 16mm (WH, DE, DR) 18mm (PR)
 Measurements are carcass size not including doors.

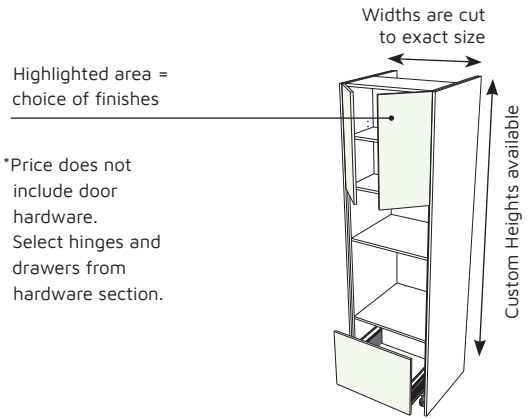

PRICE INCLUDING DRAWER FRONTS*

Product Code	Depth mm	Height mm	Custom Width mm	Trade White WH	Decorator Range DE	Designer Range DR	Premium Range PR
--------------	----------	-----------	-----------------	----------------	--------------------	-------------------	------------------

2 Drawer Oven & Microwave Unit REQUIRES 4 X STANDARD OVERLAY HINGES, 2 X 180mm DRAWER RUNNER KITS



ACOM2DR600^^	560	2050	450-600	\$313.06	\$447.79	\$597.72	\$776.20
ACOM2DR900^^	560	2050	601-900	\$405.83	\$572.77	\$706.47	\$904.96
ACHOM2DR600^^	560	2051-2250	450-600	\$329.69	\$475.26	\$634.16	\$825.94
ACHOM2DR900^^	560	2051-2250	601-900	\$426.63	\$606.11	\$750.08	\$963.89

1 Drawer Oven & Microwave Unit REQUIRES 1 X STANDARD OVERLAY HINGES, 1 X 360mm DRAWER RUNNER KITS



ACOM1DR600^^	560	2050	450-600	\$308.46	\$443.19	\$551.80	\$713.37
ACOM1DR900^^	560	2050	601-900	\$400.93	\$567.87	\$700.67	\$898.26
ACHOM1DR600^^	560	2051-2250	450-600	\$325.09	\$470.66	\$588.24	\$763.10
ACHOM1DR900^^	560	2051-2250	601-900	\$421.73	\$601.21	\$744.28	\$957.19

Under Bench Oven Unit No Drawer NO HARDWARE REQUIRED



ACU0DR600^^	560	870-880	450-600	\$104.73	\$109.74	\$116.24	\$123.94
ACU0DR900^^	560	870-880	601-900	\$123.62	\$129.39	\$137.39	\$123.94

Under Bench Oven Unit Single Drawer REQUIRES 1 X 144mm DRAWER RUNNER KIT



ACU1DR600^^	560	870-880	450-600	\$112.09	\$121.68	\$131.22	\$143.00
ACU1DR900^^	560	870-880	601-900	\$132.23	\$145.00	\$157.28	\$172.31

Single Drawer Microwave Unit 1 X 360mm DRAWER RUNNER KIT



ACM1DR600^^	560	870-880	450-600	\$149.95	\$226.02	\$285.74	\$375.04
ACM1DR900^^	560	870-880	601-900	\$190.55	\$294.18	\$374.53	\$494.92

Double Drawer Microwave Unit 2 X 360mm DRAWER RUNNER KITS



ACM2DR600^^	560	870-880	450-600	\$155.47	\$233.07	\$294.20	\$385.25
ACM2DR900^^	560	870-880	601-900	\$196.68	\$302.65	\$385.03	\$507.96

USING THIS PRICE LIST

1 Choose your cabinets

2 Select hardware - page 13

Open Shelf Cabinets

Cabinets are manufactured using the finished board colour.
MR MDF Board 16mm (WH, DE, DR) 18mm (PR)

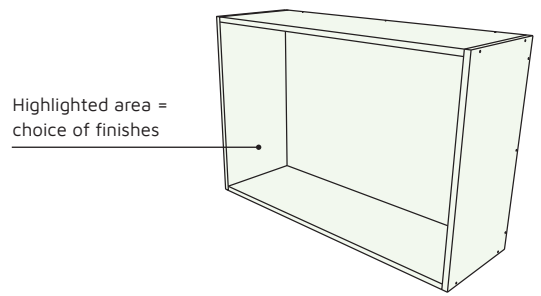

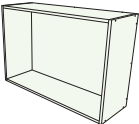
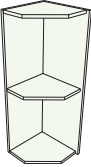
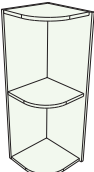
Product Code	Depth mm	Height mm	Custom Width mm	Trade White WH	Decorator Range DE	Designer Range DR	Premium Range PR
Open Cabinet No Shelf							
 OSCOS300^^	300	720	150-300	\$87.91	\$119.83	\$151.91	\$194.79
OSCOS450^^	300	720	301-450	\$96.63	\$134.23	\$170.63	\$220.23
OSCOS600^^	300	720	451-600	\$112.05	\$161.03	\$206.07	\$269.11
OSCOS750^^	300	720	601-750	\$120.76	\$175.43	\$224.79	\$294.55
OSCOS900^^	300	720	751-900	\$129.47	\$189.83	\$243.51	\$319.99
Open Cabinet Corner Angle Shelf							
 OSCCA300^^	300	720	300	\$147.91	\$179.83	\$211.91	\$254.79
Open Cabinet Corner Round Shelf							
 OSCCR300^^	300	720	300	\$147.91	\$179.83	\$211.91	\$254.79

End Panels and Kicks

Panels are manufactured using the finished board colour.
MR MDF Board 16mm (WH, DE, DR) 18mm (PR)

Product Code	Depth mm	Height mm	Width mm	Trade White WH	Decorator Range DE	Designer Range DR	Premium Range PR
End Panels							
OCEP300^^	300	720	16	\$14.93	\$22.66	\$28.92	\$39.36
BCEP600^^	600	870	16	\$27.06	\$44.14	\$57.61	\$79.47
PCEP600^^	600	2200	16	\$54.06	\$92.95	\$122.81	\$169.87
PCHEP600^^	600	2201-2400	16	\$58.37	\$100.67	\$133.12	\$184.21
Kick Panels							
KP150^^	Per Meter	150	16	\$13.53	\$19.87	\$25.19	\$34.38
KP200^^	Per Meter	200	16	\$15.38	\$23.16	\$29.58	\$40.50
KP300^^	Per Meter	300	16	\$19.06	\$29.75	\$38.38	\$52.76
L Shape Filler							
OCLF300^^	300	720	16	\$14.93	\$22.66	\$28.92	\$39.36
Base Cabinet Filler							
FP720^^	100	720	16	\$9.56	\$13.10	\$16.15	\$21.55
FP870^^	100	870	16	\$10.78	\$15.09	\$18.80	\$25.38
FP2200^^	100	2200	16	\$20.79	\$31.50	\$40.70	\$56.99
FP2400^^	100	2201-2400	16	\$22.31	\$33.99	\$44.02	\$61.78
FP1000^^	100	Per Meter	16	\$12.83	\$18.45	\$23.28	\$31.84

Hardware

Hinges

	Product Code	Brand	Description	Price
	Standard Full Overlay Hinges			
	HSOHA	Hafele	Salice 110 Degree Standard Overlay Hinge	\$2.30
	HSOBL	Blum	107 Degree Standard Overlay Hinge	\$3.34
	HSOHASC	Hafele	Silentla+ Logica Standard Overlay Hinge 105 Deg - Soft Close	\$4.20
	HSOBLSC	Blum	Blumotion Standard Overlay Hinge 110 Deg - Soft Close	\$6.84
	Blind Corner Hinges			
	HBCHA	Hafele	Salice 94 Degree Blind corner Hinge	\$5.60
	HBCBLSC	Blum	Blumotion 95 Degree Blind Corner Hinge	\$11.50
	Carcass Corner Hinges			
	HCCHA	Hafele	Duomatic 165 Degree Corner Carcass Hinge	\$6.48
	HCCBL	Blum	170 Degree Corner Carcass Hinge	\$8.24
	HCCBLSC	Blum	Blumotion 155 Degree Corner Carcass Hinge	\$15.28
	Bi-Fold Corner Hinges			
	HBCHA	Hafele	Salice 70 Degree Bi-Fold Corner Hinge	\$7.90
	HBCBL	Blum	60 Degree Bi-fold Corner Hinge	\$11.24



Drawer Configurations

Selecting Drawers Banks

Drawers can be same depth or varied. Simply choose hardware to suit the configuration you choose, and let us know when you order.



Combined height of drawer fronts = 720mm

Fixed height configurations

144mm	180mm	240mm	360mm	720mm
144mm	180mm	240mm	360mm	
144mm	180mm	240mm		
144mm	180mm	240mm		
144mm	180mm	240mm		

Popular variable height configurations

180mm	120mm	120mm	120mm
180mm	300mm	120mm	120mm
360mm	300mm	120mm	240mm
		360mm	240mm





Hardware

Drawers

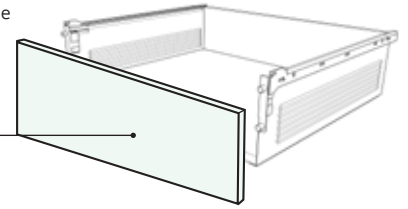
Drawers can be all same depth as per below or mixed depths (ie 2 pot drawers and 1 utensil) combine drawers for a total height of 720mm

The drawer runner kit price includes everything except the drawer front, these are ordered in the cabinet section



	Product Code	Brand	Description	Price
Suits 144mm Drawer Fronts - 5 Drawer Bank				
	DR144INNO	Hafele	Innobox dwr set 86x500mm to suit drawer fronts up to 144mm	\$20.58
	DR144ALTO	Hafele	Alto dwr set white 86x500 to suit drawer fronts up to 144mm	\$35.64
	DR144META	Blum	Metabox Drawer M 86x500mm to suit drawer fronts up to 144mm	\$22.94
	DR144BLUM	Blum	Tandembox Antaro M (65kg) 98.5X500mm to suit drawer fronts up to 180mm	\$80.86
Suits 180mm Drawer Front Heights - 4 Drawer Bank				
	DR180INNO	Hafele	Innobox dwr set 118x500mm to suit drawer fronts up to 180mm	\$22.94
	DR180ALTO	Hafele	Alto dwr set white 120x500 to suit drawer fronts up to 180mm	\$47.90
	DR180META	Blum	Metabox Drawer K 118x500mm to suit drawer fronts up to 180mm	\$27.08
	DR180BLUM	BLUM	Tandembox Antaro B (65kg) 160x500mm to suit drawer fronts up to 180mm	\$104.40
Suits 240mm Drawer Front Height - 3 Drawer Bank				
	DR240INNO	Hafele	Innobox dwr set 150x500mm to suit drawer fronts up to 240mm	\$25.36
	DR240ALTO	Hafele	Alto dwr set white 86x500 + gallery rail (h164) to suit drawer fronts up to 240mm	\$47.90
	DR240META	Blum	Drawer metabox set H 150x500mm to suit drawer fronts up to 240mm	\$31.16
	DR240BLUM	Blum	Tandembox Antaro C (65kg) 95.5X500mm with gallery rail to 196mm for drawer fronts up to 240mm high	\$134.15
Suits 360mm Drawer Front Height - 2 Drawer Bank				
	DR360INNO	Hafele	Innobox dwr set 214x500mm to suit drawer fronts up to 360mm	\$35.14
	DR360ALTO	Hafele	Alto dwr set white 86x500 + gallery rail (h240) to suit drawer fronts up to 360mm	\$52.16
	DR360META	BLUM	Drawer metabox set 241x500mm to suit drawer fronts up to 360mm	
	DR360BLUM	BLUM	Tandembox antaro d (65kg) 95.5X500mm with gallery rail to 227mm for drawer fronts up to 360mm high	
Suits Full Height - 720mm - Single Drawer Unit				
	DR720INNO	Hafele	Innobox Dwr Set 214X500mm To Suit Drawer Fronts Up To 720mm + Gallery Rail	\$27.14
	DR720ALTO	Hafele	Alto Dwr Set White 86X500 + Gallery Rail (H240) To Suit Drawer Fronts Up To 720mm	\$55.16
	DR720META	BLUM	Drawer Metabox Set 241X500mm With Gallery Rail To Suit Drawer Fronts Up To 720mm	
	DR720BLUM	BLUM	Tandembox Antaro D 95.5X500mm With Gallery Rail To 227mm For Drawer Fronts Up To 360mm High	

Benchtops

Laminate

Buy Cabinets supplies Polytec laminate benchtops, Polytec's innovative Benchtops range remains unrivalled in the decorative surfaces industry. Choose from over 150 realistic stone structures, wood grains and neutral solid colours, match the perception of authentic timber in both look and feel with WoodMatt finishes or mimic honed stone with Smooth and Matera laminates.

Stone

We also supply engineered and natural stone products from a range of suppliers, for more information talk to us directly.

Contact us for a quote: admin@buycabinets.com.au

polytec

essaSTONE™

caesarstone®

YDLSTONE

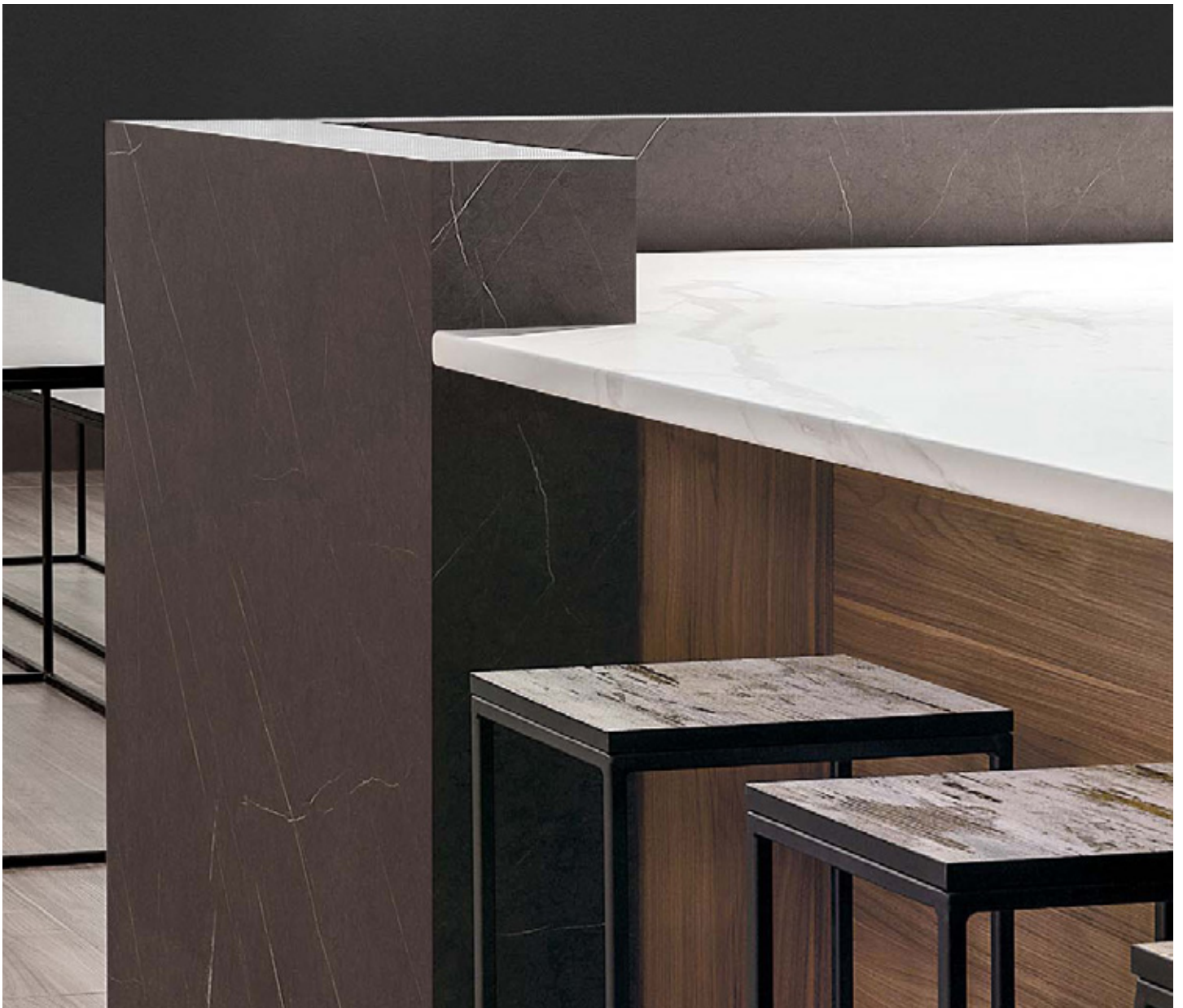

These general terms and conditions apply to sales of all Product supplied by the Seller as defined in clause 1.1 herein

1. DEFINITIONS AND INTERPRETATION

1.1 Definitions

In these terms and conditions unless expressly stated otherwise:

“Buyer” means the Person named in the relevant Sales Invoice.

“Guarantors” means the directors of the Buyer (if the Buyer is a company) as noted on the annexed Credit Application (if applicable).

“GST” means the goods and services tax as imposed by the GST Law together with any related interest, penalties, fines or other charge.

“GST Amount” means any payment (or the relevant part of that payment) multiplied by the rate of GST.

“GST Law” has the meaning given to that term in a new Tax System (Goods and Services Tax) Act 1999, or, if that Act does not exist for any reason, means any Act imposing or relating to the imposition or administration of a goods and services tax in Australia and any regulation made under the Act.

“Payment” means any amount payable pursuant to a Sales Invoice.

“Person” includes an individual, the estate of an individual, a body politic, a corporation, an association (incorporated or unincorporated) and a statutory or other authority.

“PPSA” means the Personal Property Securities Act 2009 (Cth) and any regulations made pursuant to it.

“Price” means the purchase price for the Product as provided for in the Sales Invoice total.

“Product” means any and all goods and or services provided to the Buyer by the Seller.

“Sales Invoice” means the sales invoice issued by the Seller to the Buyer in which these terms and conditions are deemed to be incorporated.

“Seller” means Star Business Investments Pty Ltd ACN 629 598 161 t/a Buy Cabinets.

“Services” means all services provided to the Buyer by the Seller.

“Tax Invoice” has the meaning given to it by the GST Law.

“Taxable Supply” has the meaning given to it by GST Law.

1.2 Interpretation:

- (a) Any terms included in a Sales Invoice that are inconsistent with this document shall prevail to the extent of the inconsistency.
- (b) Words importing the singular shall include the plural (and vice-versa).

2. GOVERNING TERMS AND CONDITIONS

The Buyer acknowledges that the Seller does not make any representations or warranties regarding the Product or any matter which is or might be relevant to the Buyer buying or selling the Product other than that which is expressly stated in this document, the Sales Invoice and any supplementary written agreement between the Buyer and the Seller.

3. TERMS OF PAYMENT

- (a) Payment to the Seller for the Product must be made in accordance with the terms agreed to between the Seller and the Buyer (these terms will be offered to the Buyer by the Seller for acceptance if Application for Credit is approved). Failure of the Buyer to make Payment in accordance with this clause shall render the Payment immediately due and payable. Interest on overdue payments shall attract interest at the rate of 10% per annum calculated on a daily basis from the due date to the date it is paid.
- (b) The costs of collection of any moneys that are due and payable by the Buyer, including the fees of any mercantile agent or lawyer engaged by a Seller shall be payable by the Buyer.

4. INSPECTION AND ACCEPTANCE

The Buyer agrees that it shall inspect the Product upon delivery. The Product shall be deemed to be accepted by the Buyer if the Seller has not received written notice from the Buyer within 7 business days of delivery of the Product that the Product is not in accordance with the Buyer’s order.

5. PASSING OF PROPERTY AND RISK

- (a) Risk in the Product shall pass to the Buyer upon delivery of the Product to the Buyer or collection of the Product by the Buyer’s agent or courier as the case may be. In the event that the Seller arranges for delivery of the Product to the Buyer, the Buyer acknowledges and agrees that the Seller will arrange, at the Buyer’s additional cost, appropriate insurance against the Product being damaged or lost in transit. The cost of such insurance will be added to the Price and payable in the same manner and on the same terms as those stipulated in clause 3 herein. In all other circumstances it will be the Buyer’s responsibility to arrange for its own insurance of the Products whilst in transit.
- (b) Property in the Product supplied by the Seller to the Buyer shall not pass to the Buyer until Payment has been made in full and the Buyer shall:
 - (i) Store such of the Product which has not been paid for separately;
 - (ii) Keep separate records in relation to the proceeds of the sale of such of the Product which has not been paid for, bank the proceeds of any such sale into a separate account and immediately remit such funds to the credit of the Seller;
 - (iii) If any of the Product is used in a manufacturing process or mixed with other materials, the Buyer shall record the value of the Product so consumed in relation to each unit of finished product and upon sale of any unit of finished product immediately remit that amount from the proceeds of sale to the Seller; and
 - (iv) If the Buyer does not pay for any Product on the due date the Seller is hereby irrevocably authorised by the Buyer to enter the Buyer’s premises (or any premises under the control of the Buyer or as agent of the Buyer if the Product is stored at such premises) and use reasonable force to re-take possession of the Product without liability for the tort of trespass, negligence or payment of any compensation to the Buyer whatsoever. The Buyer also agrees to indemnify the Seller against the reasonable costs of removal, enforcement and/or legal action in respect of the removal of any goods under this clause.
- (c) The Buyer and Seller agree that the provisions of this clause apply notwithstanding any arrangement under which that Seller grants credit to the Buyer.

6. SUSPENSION OR TERMINATION OF CREDIT FACILITY

The Seller may, at any time without notice, terminate or suspend the Buyer’s right to purchase the Product upon credit and the Seller shall not be liable to the Buyer for any loss or damage the Buyer may sustain as a result of such refusal.

7. DEFAULT OF BUYER

If these terms and conditions are not strictly observed by the Buyer, the Seller may in its absolute discretion, refuse to supply to the Buyer and the Seller shall not be liable to the Buyer for any loss or damage the Buyer may sustain as a result of such refusal.

8. RETURNS

- (a) Returns will be accepted for faulty or defective Product or any other non-excludable obligations of the Seller set out in the Competition and Consumer Act 2010 (Cth), or similar State and Territory legislation.
- (b) Returns other than those referred to in (a) above, must be approved by the Seller in its absolute discretion. These authorised returns must be freight prepaid and will only be accepted if they are in a saleable condition. Notwithstanding the Seller’s approval of returns pursuant to this clause, the Seller reserves the right to charge a handling fee equal to 15% of the price of the returned Product. Product specifically purchased, manufactured, machined or cut to size or to the Buyer’s specification or are provided exclusively by the Buyer are not returnable unless they are of the kind referred to in (a) above.

Terms and Conditions of Sale (continued)

9. SUPPLY

The Seller reserves the right to suspend or discontinue the supply of Product to the Buyer without being obliged to give any reason for its action.

10. INSTALLATION

The Seller's Sale Invoice is made on a supply only basis. Installation and commissioning (if any) is at the expense of the Buyer unless otherwise specified in writing by the relevant Seller. The Seller shall not be responsible or liable for any costs, expenses, losses or damages for, or arising out of, any installation or commissioning.

11. DESCRIPTIONS

- (a) Photographs, drawing illustrations, weights, dimensions and any other particulars accompanying, associated with or given in a Quotation, descriptive literature or a catalogue, approximate the Product offered but may be subject to alteration without notice.
- (b) Any performance data provided by the Seller or a manufacturer is an estimate only and should be construed accordingly.

12. SHIPMENT AND DELIVERY

- (a) Upon acceptance of any order by the Seller the Seller will seek confirmation of the period of shipment or delivery. If any variation has occurred in the quoted period (which will delay delivery by more than 14 days) the Seller will notify the Buyer. Unless the Buyer objects in writing within 7 days of that notification to the Buyer, the period of shipment or delivery notified to the Buyer will be the contractual period for shipment or delivery. The Buyer acknowledges and agrees that the period of shipment or delivery quotes by the Seller is an estimate only and may be varied unilaterally by the Seller but (not by more than 14 days).
- (b) A delivery charge may apply to deliveries with the exception of back order deliveries which are part of an original order that has been partly fulfilled.
- (c) Unless otherwise agreed in writing, if the Seller prepays freight, insurance, custom and import duties (if any), landing and delivery charges and all other charges in connection with shipment and delivery of the Product, then any such charges shall be to the Buyer's account. The Seller reserves the right to nominate the means of delivery.
- (d) The Seller reserves the right to make part deliveries of any order, and each part delivery shall constitute a separate sale of the Product upon these terms and conditions. A part delivery of an order shall not invalidate the balance of an order.
- (e) The Seller shall not be responsible or liable for any costs, expenses, losses or damages for delay in the delivery or supply of the Product.
- (f) The Buyer shall be responsible or liable for any costs, expenses, losses or damages for deliveries in emptying and returning shipping containers used to deliver the Products to the Buyer (including but not necessarily limited to container detention fees, redirecting fees and storage fees).

13. VARIATION BY MANUFACTURER

Where the Seller is acting as agent for a manufacturer or supplier, the Seller shall not be liable for any alteration or variation in the Product made by the manufacturer or the supplier.

14. CURRENCY

Where the Product is imported into or exported from Australia, any adverse variation in the price arising from fluctuation in exchange rates between the date of the Buyer's order and the date of payment by the Seller will be to the Buyer's account.

15. CONTINGENT EXPENSES

Any charge, duty, impost, sales tax or other expenditure which is not applicable at the date of Sales Invoice but which is subsequently levied upon a Seller in relation to a Sales Invoice as a result of the introduction of any legislation, regulation or government policy, shall be to the Buyer's account.

16. FORCE MAJEURE

If by reason of any fact, circumstance, matter or thing beyond the reasonable control of the Seller or the Buyer, either is unable to perform in whole or in part any obligation under this agreement, such party shall be relieved of that obligation under

this agreement to the extent and for the period that it is so unable to perform and shall not be liable to the other party to this agreement in respect of such inability.

17. BUYER'S CANCELLATION

Unless otherwise agreed in writing, the Buyer shall have no right to cancel an order which has been accepted by a Seller. If a right of cancellation is expressly reserved to the Buyer in writing, such right of cancellation must be exercised by notice in writing from the Buyer to the Seller not later than 28 days prior to the estimated date of shipment by the Seller. Unless otherwise agreed between the Buyer and the Seller, any cancellation by the Buyer prior to shipment shall immediately render any deposit paid by the Buyer to be forfeited to the Seller and the Buyer is liable for 50% of the invoice value of the order cancelled (less any deposit forfeited).

18. LIABILITY

- (a) The Seller will not be liable for any claims, losses or damages arising out of or in respect to the supply and/or manufacture of the Product including, but not limited to, claims for faulty design, negligent or misleading advice, damages arising from loss or use of the Product, and any direct, special or consequential damages or injury to any person, corporation or other entity.
- (b) The Seller makes no express warranties under this Agreement except that to the extent that the Product supplied is covered by the manufacturer's warranty, the Seller will pass onto the Buyer the benefit of the manufacturer's warranty.
- (c) Upon discovery of any defect in the Product supplied by a Seller the Buyer shall immediately notify the Seller in writing. The Buyer shall not carry out any remedial work to allegedly defective Product without first obtaining the written consent of the Seller to do so.
- (d) The Seller excludes all conditions, warranties and terms, whether expressed or implied by law or otherwise in respect of the Product which may apart from this clause be binding upon the Seller, except any implied conditions and warranties the exclusion of which would contravene any statute or cause this clause to be void.
- (e) The Buyer expressly acknowledges and agrees that it has not relied upon, any advice given by the Seller, its agents or employees in relation to the suitability for any purpose of the Product supplied by the Seller.
- (g) In the event that the Buyer (or a third party directed by the Buyer) provides to the Seller any plans, designs or specifications in relation to a Product that the Buyer requires the Seller to fabricate, manufacture and/or supply to the Buyer, whether directly by the Seller or through any third party, the Buyer unconditionally and irrevocably indemnifies the Seller from and against any and all liability, claims, damages, losses and/or reasonable costs (including but not limited to any demands, actions, proceedings and/or claims brought against the Seller by a third party alleging infringement of intellectual property rights owned or controlled by the third party in respect of the Product or such plans, designs or specifications provided by the Buyer).

19. ALTERATION TO CONDITIONS

The Seller may, at any time and from time to time, alter these terms and conditions.

20. GST

The parties agree that:

- (a) the Price is inclusive of GST;
- (b) all other Payments have been calculated without regard to GST;
- (c) each party will comply with its obligations under the Trade Practices Act 1974 when calculating the amount of any Payment and the amount of any relevant Payments will be adjusted accordingly;
- (d) if the whole or any part of any Payment is the consideration for a Taxable Supply (other than for payment of the Price) for which the payee is liable to GST, the payer must pay to the payee an additional amount equal to the GST Amount, either concurrently with that Payment or as otherwise agreed in writing;

Terms and Conditions of Sale (continued)

20. GST (continued)

- (e) any reference to a cost or expense in this Agreement excludes any amount in respect of GST forming part of the relevant cost or expense when incurred by the relevant party for which that party can claim an Input Tax Credit, and the payee will provide to the payer a Tax Invoice.

21. CHARGE IN LAND

- (a) By executing this Credit Application the Buyer and if the Buyer is a company, each of the Directors of the Buyer ("the Directors"), hereby create an interest in land and charge in favour of the Seller in respect of all real estate, land and buildings owned by the Buyer and/or the Directors of the Buyer.
- (b) To better secure the interest in land and charge given by clause 21 (a) the Buyer and the Directors hereby consent to the Seller lodging and registering a caveat on the titles of each and any piece or parcel of land owned by the Buyer and each and any piece or parcel of land owned by the Directors or any of them.

22. POWER OF ATTORNEY

The Applicant and the Directors warrant and agree that they will when called upon by the Buyer and/or each/all of the owners of the business to so do, expeditiously sign any consent or other document required by the Department of Environment and Resource Management (or its replacement controlling the registration of caveats) to cause or permit the registration of any such caveat. If the Applicant or any Director refuses or neglects to execute such consent or other document, the Applicant and each of the directors hereby duly appoint the business owners or each of them as its/their lawful attorney to execute such consent or other document on its/their behalf. The Applicant and the Directors indemnify and hold harmless the business for cost of preparing and registering such caveat.

23. PERSONAL GUARANTEE

In consideration for the Seller providing the Product to the Buyer, the Guarantors (and if more than one then jointly and severally) hereby guarantees to the Seller the obligations of the Buyer pursuant to these Terms and conditions, particularly, but not necessarily limited to, the payment of any and all monies by the Buyer to the Seller.

24. GOVERNING LAW

These terms and conditions and any contract including them shall be governed by and construed in accordance with the laws of the State of Queensland and the Seller and Buyer submit to the non-exclusive jurisdiction of the Courts of Queensland.

25. TERMS & CONDITIONS TO CONTINUE TO APPLY

The terms of this Agreement are continuing and apply to all subsequent sales by SBI to the Applicant.

26. PPSA

- 26.1 The Buyer acknowledges that the Seller has a security interest (for the purposes of the PPSA) in the Product and any proceeds from the on-sale thereof until the title in and to the Product passes to the Buyer in accordance with clause 5(b). This security interest secures all moneys owing by the Buyer to the Seller (including the Price of the Product) under any contract or otherwise ("the Amounts Owing");
- 26.2 The Buyer acknowledges that each security interest over Product (or their proceeds) arising under this clause 26 is a purchase money security interest to the extent that it secures payment of the Amounts Owing in relation to that particular Product;
- 26.3 The Buyer must not assign or grant a security interest in

respect of any accounts owed to it in relation to the Product without the Seller's prior written consent. The Company has a security interest in all such accounts to secure the Amounts Owing;

- 26.4 The Buyer consents to the Seller effecting a registration on the PPSA Register (in any manner the Seller considers appropriate) in relation to any security interest contemplated by these Conditions of Sale and the Buyer agrees to provide all assistance reasonably required to facilitate this;
- 26.5 The security interests arising under this clause 26 attach to the Product when the Purchaser obtains possession of the Product and the Buyer and the Seller confirm that they have not agreed that any security interests arising under this clause 26 attach at any later time;
- 26.6 In addition to any rights the Seller may have under Chapter 4 of the PPSA the Seller shall be entitled at any time until the title in and to the Product passes to the Buyer in accordance with clause 5(b):
- (a) to demand the return of the Product, upon which the Buyer must immediately return to the Seller that Product;
- (b) to the extent permitted by law, to enter (or have its representative enter) any premises occupied by the Buyer in order to search for and remove the Product without notice to the Buyer and without liability to the Buyer (including liability in relation to negligence). The Buyer and its representatives shall provide all reasonable assistance to the Seller and its representatives for this purpose; and
- (c) to retain, sell or otherwise dispose of that Product on any terms and in any manner it sees fit and, subject to section 140 of the PPSA, may apply the proceeds to repay any debt owed to it by the Buyer;
- 26.7 If there is any inconsistency between the rights of the Seller under clause 26 and its rights under Chapter 4 of the PPSA, clause 26 prevails to the extent permitted by law;
- 26.8 The Buyer indemnifies the Seller against any claim (including negligence) in respect of any damage to the property of, or the premises occupied by, the Buyer or any consequential loss or pure economic loss caused by another party when searching for and removing the Goods in accordance with clause 26.6.

27. SET-OFF

27.1 The Buyer agrees that:

- (a) The Seller may set-off any credit amount that the Seller owes to the Buyer against any debt due by Buyer to the Seller at the Seller's sole discretion; and
- (b) The Buyer is not entitled to withhold payment of any money in respect of any alleged set-off or claim the Buyer might have against the Seller.

28. SEVERANCE AND WAIVER

- 28.1 If any part of this agreement is found to be void, unlawful, or unenforceable then that part will be deemed to be severed from the agreement and the severed part will not affect the validity and enforceability of any remaining provisions. Any waiver of the Seller's right under this agreement must be in writing and signed by an authorised representative of the Seller.

Limited Manufacturer's Warranty for Buy Cabinets Timber Joinery Products

Our goods come with guarantees that cannot be excluded under the Australian Consumer Law. You are entitled to a replacement or refund for a major failure and for compensation for any other reasonably foreseeable loss or damage. You are also entitled to have the goods repaired or replaced if the goods fail to be of acceptable quality and the failure does not amount to a major failure.

The Warranty

We warrant that the Product is free from defects in workmanship and materials for the Warranty Period.

What we must do if the Product is Defective

Subject to the conditions of warranty set out in clause 3, if the Product is found to be defective and is returned to the place of purchase at your expense during the Warranty Period, we will repair or replace the Product free of charge.

What Products are Covered Under the Warranty

This limited warranty applies to domestic use only, and covers defects in material and workmanship in the following components of the Buy Cabinets wardrobes and interior organizers

- Frames
- Shelves
- Draw Boxes
- Doors
- Door Tracks
- Hang Rails

What Products are Not Covered Under the Warranty

- Draw Runners
- Hinges
- Wheels
- Guides
- Pull out racks
- Spinning Corner Organiser
- Pull out mirror

What you must do to Claim Under the Warranty

In order to claim under the Warranty, you must:

- 3.1 Be able to show that the damage or defect has arisen solely from faulty materials or manufacture;
- 3.2 Be able to show that the Product has not been misused, mistreated, damaged or neglected by physical means including but not limited to, fair wear and tear, natural colour variations or fading, faulty installation or damage caused by refitting small replacement items, overloading or movement caused by natural movement of other structures, pests, accidents or acts of God, after purchase;
- 3.3 Be able to show that you have fulfilled your Product Maintenance Obligations;
- 3.4 Be able to show that the Product has not been used, including altered, modified or repaired, in a manner inconsistent with the Prescribed Purpose;
- 3.5 Be able to show that the Product has not at any time been:
 - a. Exposed to excessive heat, moisture, ultra-violet or physical or chemical abuse (such as floor and paint strippers and other harsh or inappropriate cleaning chemicals i.e. bleach);
 - b. Installed in a portable or mobile building or structure, including but not limited to a caravan or boat;
 - c. Re-installed at a location other than the original installation site; or
 - d. Inadequately supported by any structure to which it is installed;
- 3.6 Be able to show that the Product was inspected and

accepted within forty-eight (48) hours of the purchase;

- 3.7 Be able to show that you are the original purchaser by production of the original receipt of purchase clearly showing the Date of Purchase;
- 3.8 Pay all transportation charges incurred in returning the defective Product (or parts thereof) for repair, together with the cost of returning them to you.

Other Important Information in Relation to the Warranty

- 4.1 Our Liability pursuant to this Warranty is (to the extent it is lawful to do so) limited to the cost of repair or replacement of the Product. We shall not in any circumstances be liable for physical or financial injury, loss or damage or for consequential loss or damage of any kind arising from the Product or its use or application by you.
- 4.2 This Warranty is non-transferable and does not apply to any purchaser who bought the product from a reseller or distributor not authorised by us, including but not limited to purchases from internet auction sites or purchases considered as second-hand goods.
- 4.3 Should the Product prove to be irreparable, we reserve the right to substitute an equivalent product if available or to retract the Warranty if no replacement is available.
- 4.4 The benefits provided to you by the Warranty are in addition to other rights and remedies available to you.

Who is Giving the Warranty?

The entity giving the Warranty is:

Star Business Investments Pty Ltd trading as Buy Cabinets
ACN 629 598 161 9 Nevilles Street, UNDERWOOD QLD 4119
Phone: (07) 3208 6799 Email: admin@buycabinets.com.au

Definitions

"the Date of Purchase" means the date the Product is purchased and fully paid for from an authorised retailer as evidenced by the properly dated receipt issued to you at the time of purchase on or after 1st July 2019.

"Product Maintenance Obligations" means cleaning the Product with high performance thinners. Although the timber joinery products are defined as moisture resistant, there is a likelihood of some swelling in thickness and change in dimensions if they are exposed to the elements for protracted periods. Care must be taken to avoid excessive amounts of water remaining in contact with your Product and to ensure the Product is not neglected in storage or on site. Harsh or inappropriate cleaning chemicals, i.e. bleach, must never be used to clean your Product.

"the Product" means Buy Cabinets timber joinery products.

"We, Our or Us" means Star Business Investments Pty Ltd trading as Buy Cabinets.

"the Warranty Period" means ten (10) years from the Date of Purchase.

"the Prescribed Purpose" means for use solely and exclusively as a storage unit for personal domestic and household use.

"You" means the purchaser of the Product.